



NO.	ITEM	SOECUFUCATION	NOTES											
1-1	Input frequency range	900.0MHz~2150.0MHz	SP5655 (TEMIC)											
1-2	One input connector	F Type, Female												
1-3	Nominal input impedance	75 Ohm												
1-4	Tuning circuit	Built in PLL												
1-5	IF frequency	479.50 MHz center												
1-6	IF band width	27 MHz nominal												
1-7	Demodulation	Phase locked loop												
1-8	Vedio output polarity	Positive going												
1-9	Operating voltage	+28V(+/-5%)(tuing) +5v (+/-5%)(B+)												
1-10	Operating temprature	-10°C~+60°C												
1-11	Operating humidity	Less than 80% R.H. (at 40°C)												
1-12	Storage temperature	-20°C~+70°C												
1-13	Storage humidity	Less than 95% R.H. (at 40°C)												
1-14	Input level	-60~-30dBm												
2.	Standard test condition	Test for electrical specification shall be preformed at following condition unless otherwise specified.												
2-1	Ambient condition	Temperature 25°C+/-2°C Humidity 65°C+/-5°C If no doubt on test results temperature +5°C~+30°C and humidity 45%~80% R.H could be applied.												
2-2	Measurement to start	30 minutes after DC power supplied.												
2-3	Power supply	<table border="1"> <thead> <tr> <th>Terminal</th> <th>Supply voltage</th> </tr> </thead> <tbody> <tr> <td>LNB power</td> <td></td> </tr> <tr> <td>+5V</td> <td>+5V(+/-)0.1V</td> </tr> <tr> <td>+28V</td> <td>+28V(+/-)0.1V</td> </tr> <tr> <td>SDA</td> <td>specified tuning</td> </tr> <tr> <td>SCL</td> <td>pulse</td> </tr> </tbody> </table>		Terminal	Supply voltage	LNB power		+5V	+5V(+/-)0.1V	+28V	+28V(+/-)0.1V	SDA	specified tuning	SCL
Terminal	Supply voltage													
LNB power														
+5V	+5V(+/-)0.1V													
+28V	+28V(+/-)0.1V													
SDA	specified tuning													
SCL	pulse													



NO.	ITEM	Specification					NOTES
3.	Current consumption	Terminal	MIN.	TYP.	MAX.		
		+5V	190	240	290	mA	
		+28V	0.5	1.0	3.0	mA	
4.	Absolute maximum voltage	Terminal	MAX. Supply voltage				
		LNB power	DC +25V				
		+5V	DC +5.25V				
		+28V	DC +30V				
		SDA,SCL	0V to the same voltage as +5V terminal				
5.	Electrical specification	Terminal	Max. take off current				
		LNB power	500mA				
		B.B output	0.5mA				
		Under standard test condition test channel:DBS 20 CH input level :-45dBm unless otherwise specified.					
		Condition	MIN.	TYP.	MAX.		
5-1.	Input VSWR	900MHz~2150MHz		2.0	3.0		
5-2.	Noise figure	900.0 MHz ~2150 MHz		8.0	12.0	AGC fullgain dB	
5-3.	Local leakage at input terminal	900MHz~1750MHz 1750MHz~2150MHz		-70	-63 -50	dBm	
5-4.	Tuning voltage curve	900 MHz 950 MHz 1150 MHz 1250 MHz 1450 MHz 1650 MHz 1850 MHz 2050 MHz 2150 MHz	1	1.6 2.2 4.0 5.0 7.0 9.2 12.1 15.9 21.0	26.6	V	



NO	ITEM	Specification				NOTES	
		Condition	MIN.	TYP.	MAX.		
5-5.	Local oscillator +B shift	Tuning voltage shift with +B +/- 5%		+10		MHz	
5-6.	Local oscillator temperature drift	Tuning voltage shift with -10°C~+60°C		+10		MHz	
5-7.	IF 3dB bandwidth			27		MHz	
5-8.	Window AFT input on P6	Center Error (f0)	-1		+1		
		Center Voltage	0.14	2.5	4.88		
		Sensitive	2	3	4		
		A2	A1	A0	Frequency	Voltage	
1	0	0	Too Low	3 ~ 13.2V			
0	1	1	Correct	2.25 ~ 3 V			
0	1	0	Correct	1.5 ~ 2.25V			
0	0	1	Correct	0.75 ~ 1.5V			
0	0	0	Too High	0.0 ~ 0.75V			
5-9.	B.B output characteristics (1) Video output level	Video waveform white 100% pal frequency deviation 16MHz p-p without pre-emphasis					
		White to sync.	0.55	0.75	0.95	Vp-p	
	(2) Gain-frequency response	Test modulation frequency :60Hz~8MHz without energy dispaal modulation reference freq. 100KHz IF BW 27MHz					
		Freq. response		+1	+3	dB	
	(3) Group delay response	Test frequency :60Hz~8MHz without energy dispaal modulation reference freq. 100KHz IF BW 27MHz					
Group			+10	+50	nsec		



NO	ITEM	Specification	NOTES			
	(4) DG/DP	10 step staircase 16MHz p-p PAL without energy dispasal modulation positive video amplifier with de-emphasis should be applied IF BW 27MHz				
		DG (APL 50%)		2	2	%
		DP (APL 50%)		2	5.0	°
	(5) SN RATIO	Input C/N =14dB (noise BW 27MHz) white 100% video 16MHz p-p PAL with audio subcarrier modulation 3.4MHz p-p DEV. @6.5MHz positive video amplifier with de-emphasis should be applied 100Hz~5MHz unweighted SN FOR:power on reset indicator				
		SN		34.0	36.0	dB
	(6) Static threshold		6.0	8.0	dB	
7-1.	Signal level out voltage	(V)Signal level out <p style="text-align: center;">-30 -45 -60 -80 INPUT LEVEL (dBm)</p>	47K OHM loaded			
7-2.	I ² C BSU (1) SDA,SCL Input voltage	Under standard test condition				V
		Condition	MIN.	TYP.	MAX.	
		High voltage	3		5	
	Low voltage	0		1.5		
	(2) Address	C2 (on write data format)				
	(3) SDA,SCL Input impedance	SDA/SCL are in the high impedance and there should be no reliablity problem with 5V continually on the SDA/SCL,if power supply is switched off.				

(4) Data format

	MSB					LSB				
Address	1	1	0	0	0	MA1	MA0	0	A	BYTE1
programmable divider		14	13	12	11	10	9	8		
	0	2	2	2	2	2	2	2	A	BYTE2
Programmable divider	7	6	5	4	3	2	1	0		
	2	2	2	2	2	2	2	2	A	BYTE3
Charge pump and test								(0)		
	1	CP	T1	T0	1	1	1	OS	A	BYTE4
I/O port control bits										
	P7	P6	P5	P4	P3	P2	P1	P0	A	BYTE5

Table 1 write data format (MSB is transmitted first)

Address	1	1	0	0	0	MA1	MA0	0	A	BYTE1
Status byte	POR	FL	I2	I1	I0	A2	A1	A0	A	BYTE2

Table 2 read data format

A:acknowledge bit.

MA1,MA0:voltage address bits.

CP:charge pump current select.

T1:test mode selection.

T0:charge pump disable.

OS:varactor drive output disable switch.

P7,P6,P5,P4,P3,P2,P1,P0:control output states.

POR:power on reset indicator

FL:phase lock detect flag.

I2,I1,I0:digital information from ports P7,P5 and P4

A2,A1,A0:5 level ADC data from P6.

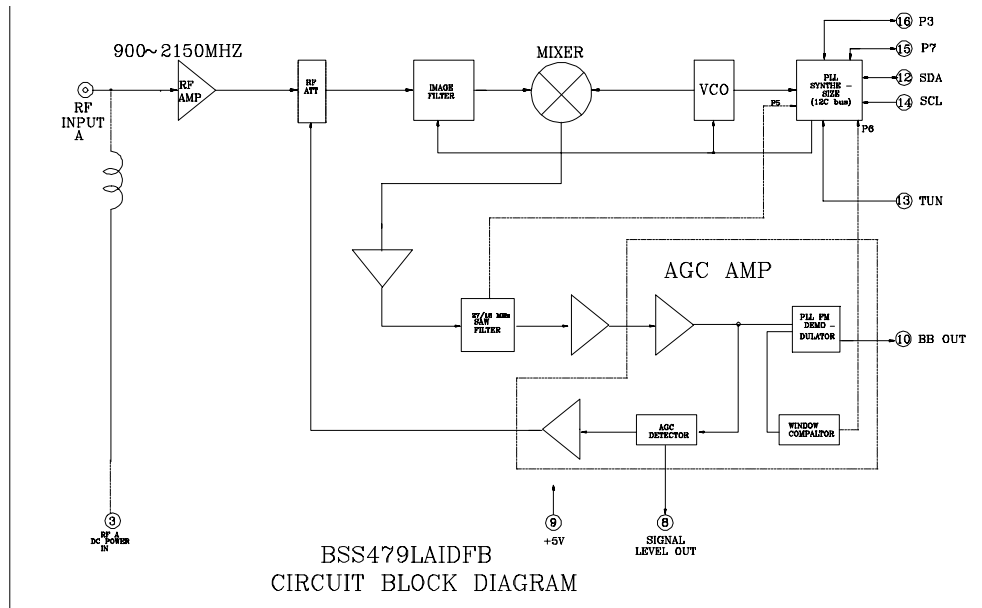

PCB LAYOUT REFERENCE POSITION:

NOTE 1. TOLERANCES ARE ±0.5.
UNLESS OTHERWISE SPECIFIED.

PIN NO.	CONTENTS
1	-----
2	-----
3	LNBA
4	-----
5	-----
6	-----
7	-----
8	AGC OUT
9	5V
10	B.B
11	-----
12	SDA
13	TUV
14	SCL
15	P7
16	P3

CUSTOM MODEL	
COMTECH MODEL	BSS479LAIDFB(5/5)

DATE	REV	BY	FILE
DATE	REV	BY	FILE
DATE	REV	BY	FILE

COMTECH TECHNOLOGY CO., LTD.